



Part No. 918200

Model CT200S24
Cordless 18 Ga
Straight Brad Finish Nailer



CLEANING PROCEDURE

www.paslode.com

Literature Part Number: 918234

This procedure provides a simple but effective way to clean your Paslode Cordless tool and maintain reliable operation. Regular cleaning and lubrication will also extend part life and provide maximum nail driving power.

To disassemble the tool for cleaning, only a flat head screwdriver and the 9/64" Hex Key Wrench provided with the tool are needed.

Paslode® recommends that an aerosol "Tool Cleaner", such as Paslode Tool Cleaner (Part No. 219348), be used for cleaning. This cleaner is available through your local Paslode Dealer.

If a different type of Degreaser Cleaner is selected, make sure that it will not damage plastic and electrical parts. Chemical damage to electrical parts may result in the tool being made inoperable.

To begin, you will need the following items:

1. Flat Head Screwdriver
2. Hex Key Wrench (provided with tool)
3. Paslode Tool Cleaner #219348
4. Paslode Lubricating Oil #401482
5. Clean Lint Free Rag



DANGER

Remove all fasteners, fuel, and battery prior to servicing the tool.

Step 1

Use the 9/64" Hex Key Wrench (#900736) to unscrew the 2 Socket Head Cap Screws that attach the sides of the cap.



Step 2

Use the Wrench to unscrew the 4 Socket Head Cap Screws that attach the top of the cap.





Step 3

Remove filter by hand and clean with mild soap or replace if necessary.

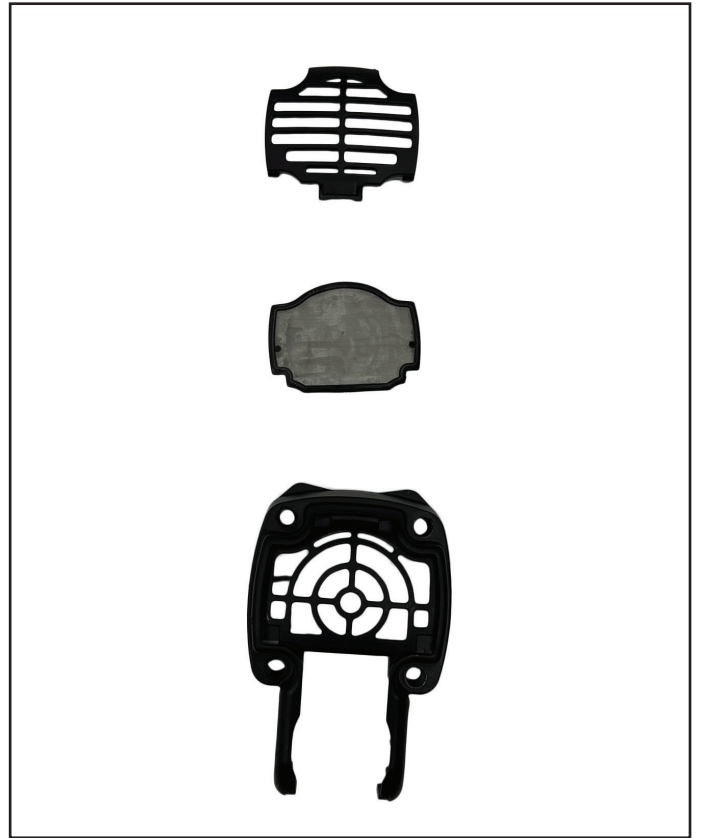

Set the grill, filter, and cap aside.



Step 4

Carefully unplug the Electrical Connector to the Fan Motor Circuit Board and the Spark Plug Wire.

NOTE: Position of wires in the wire clip is critical. Placing the wires outside the wire clip can cause electrical damage to the tool.

Step 5

Rotate the **Cylinder Head Assembly** clockwise 1/8 of a turn and lift the cylinder head from the **Motor Assembly**.

ROTATE CLOCKWISE

Step 6

You have now separated the tool into the two major assemblies, allowing access to the areas that require periodic cleaning and lubrication.

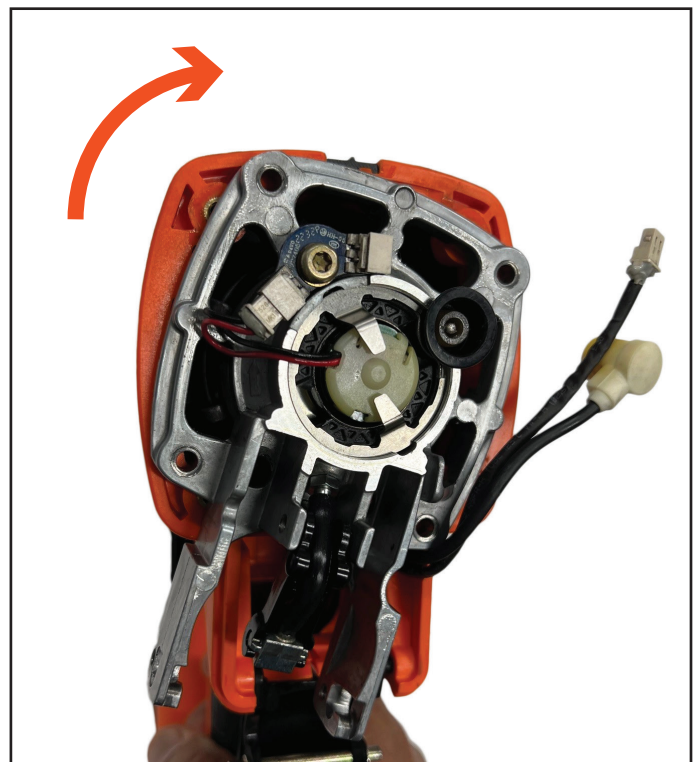

DANGER

Never operate the Paslode Cordless tool unless all six Socket Head Cap Screws are firmly tightened on the cylinder head. Failure to do this could result in tool damage, fire and personal injury.



Step 7

Spray the Cylinder Head with Cordless Tool Cleaner. Allow the dirt and debris to drip off.



Step 8

Using a clean, lint free rag, wipe off any remaining cleaner or dirt. Make sure the **Seal Rings** and **Spark Plug** are completely clean and clear of debris. Repeat Step 7 to remove any heavy deposits or residue.

Step 9

Lightly lubricate the Seal Rings with **Paslode Lubricating Oil**, part #401482. Make sure oil is applied evenly around the **Seal Rings**. Set the **Cylinder Head Assembly** aside.

Note: Paslode Lubricating Oil is specially formulated for use in the Paslode Cordless Tool. The use of other types of lubricants may cause rapid build-up of combustion residue or result in premature part failure.

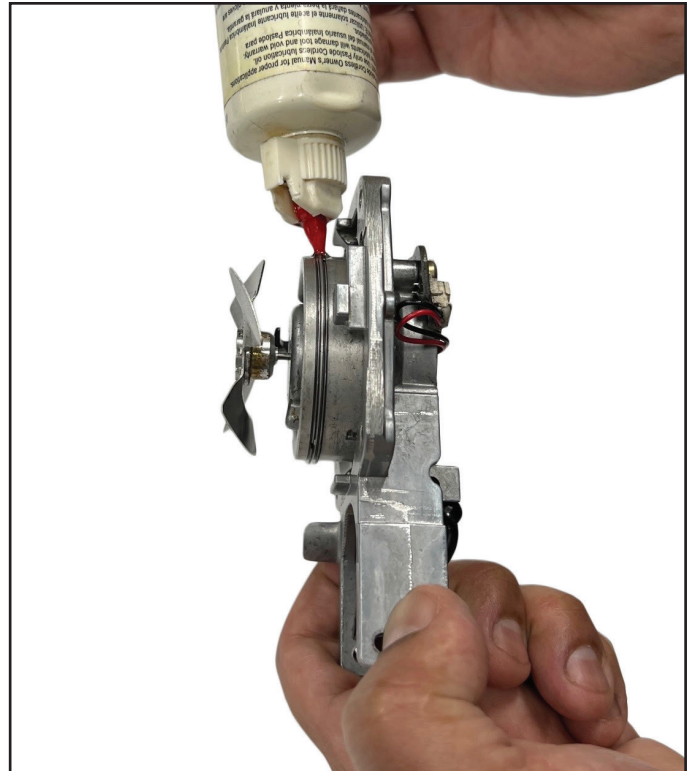

Step 10

Push the Piston Assembly to the "down position" using a screwdriver handle or a clean piece of wood.





Step 11

Spray a liberal amount of tool cleaner into the inside of the **Sleeve and Combustion Chamber**. Invert the **Motor Assembly**, and let excess cleaner and dirt drain out.



Step 12

Using a clean area of a lint-free rag, wipe off any remaining cleaner or dirt. Repeat Steps 11 and 12 to remove any heavy deposits or remaining residue.

Step 13

With **Motor Assembly** tilted up, squeeze 4-5 drops of **Paslode Lubricating Oil** into **Sleeve** (Area "A") and 3-4 drops onto lower lip of **Combustion Chamber** (Area "B") and apply 4-5 drops around the top of the **Combustion Chamber** (area C). Rotate **Motor Assembly** while oiling to ensure oil is evenly distributed around **Sleeve** and **Combustion Chamber**.

See **Tool Cutaway Illustration** on page 10.

Note: Do not over oil the tool.

Excessive oiling may cause staining of work surface.



Step 14

Hold **Motor Assembly** upright, and push down and release several times to allow oil on lower lip of **Combustion Chamber** to be evenly distributed.



Step 15

Manually push the **Driver Blade** up and down to distribute the oil in the **Sleeve** evenly.

Reassemble the **Paslode Cordless** tool following disassembly Steps 1-4, pages 2-3 in **Reverse** order.

Reassembly Note:

Before tightening **Cap Screws**, depress the nose of the tool down on its work contacting element to close Combustion Chamber. Make sure cylinder head is centered to the motor, and that the **Cap Assembly** does not pinch exposed wires. **Cap Screws** must be tightened securely before using tool.



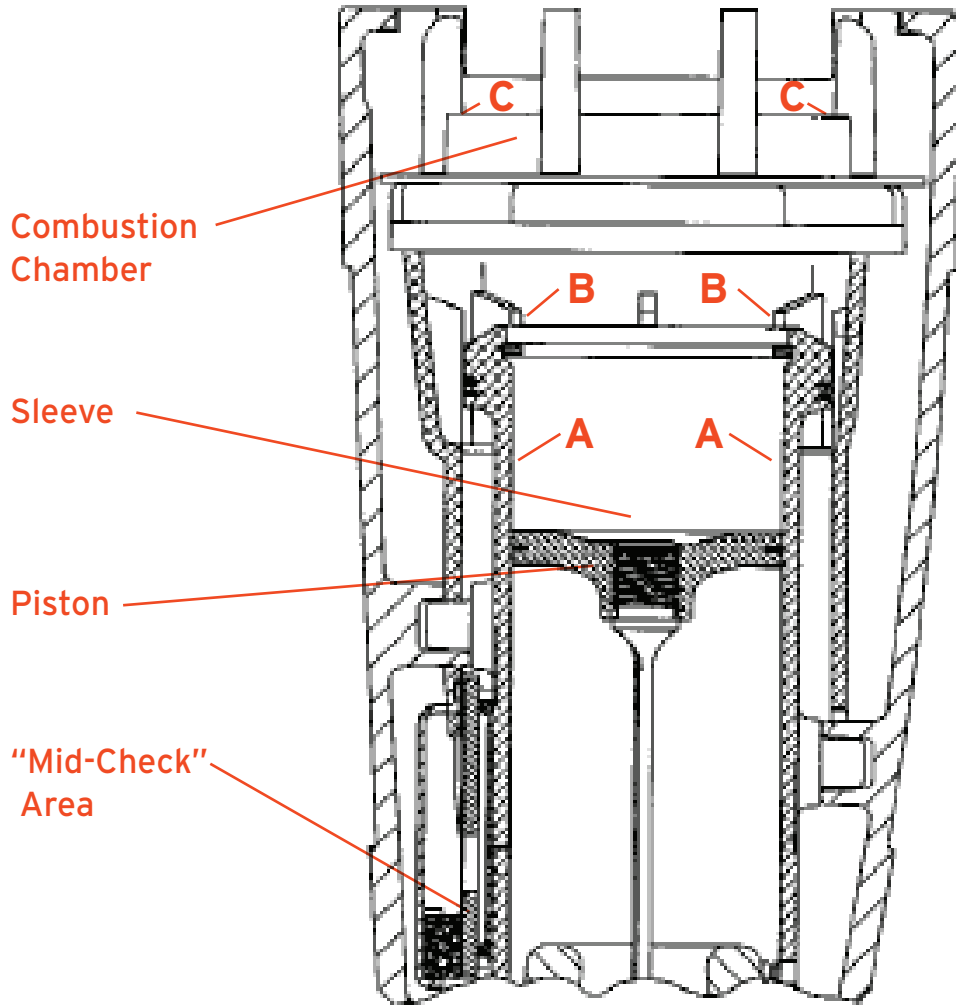

**Tool
Cutaway
Illustration**

Motor Assembly



DANGER

Do not attempt to operate the tool unless the cap assembly is securely attached to the housing. Operating the Paslode Cordless tool with a loose or missing cap assembly can result in the escape of burning gases, tool damage, and injury to tool user and property.

NOTE

After the tool is completely reassembled and all screws are tightened, test the tool for proper operation. Some smoke may be noticeable from the exhaust ports on the first few cycles as excess oil is burned off. Consult the operating manual for instructions if the tool malfunctions.

CLEANING INTERVAL CHART

Very Dirty	●	●				
Dirty	●●	●●	●	●	●	
Moderate	◆	◆	●●	●●	●●	
Clean	■	■	◆	◆	◆	
	0	2m	4m	6m	8m	10m

Recommended Cleaning Interval

- Every 2-3 Days
- Every Week
- Every 2 Weeks
- ◆ Every Month
- Every 2 Months

The maintenance interval for cleaning the **Paslode Cordless Nailer** will vary depending upon the number of nails driven per week, and the operating conditions under which the tool is used.

When the **Paslode Cordless Nailer** is used in a dirty environment or at high nailing rates for extended periods, cleaning should be performed at shorter intervals.

Paslode has developed this chart as a guideline to assist you in establishing the proper cleaning schedule for the type of

use the tool is getting. If you find that the suggested cleaning interval is allowing the tool to become excessively dirty between cleanings, reduce the interval to the next shorter frequency. If it is apparent that the Paslode Cordless Tool is not in need of cleaning at the scheduled time, increase the interval to the next longer period.

If you have any questions regarding this chart or any of the instructions in this cleaning procedure, contact your Paslode distributor for assistance.

Paslode Cordless 18 Ga Straight Brad Finish Nailer CLEANING PROCEDURE

Part No. 918200

Model CT200S24

**For Technical Support call:
1-800-222-6990
Go to: paslode.com
to find Parts and Service Centers**



**An Illinois Tool Works Company
155 Harlem Avenue
Glenview, IL 60025
www.paslode.com**