

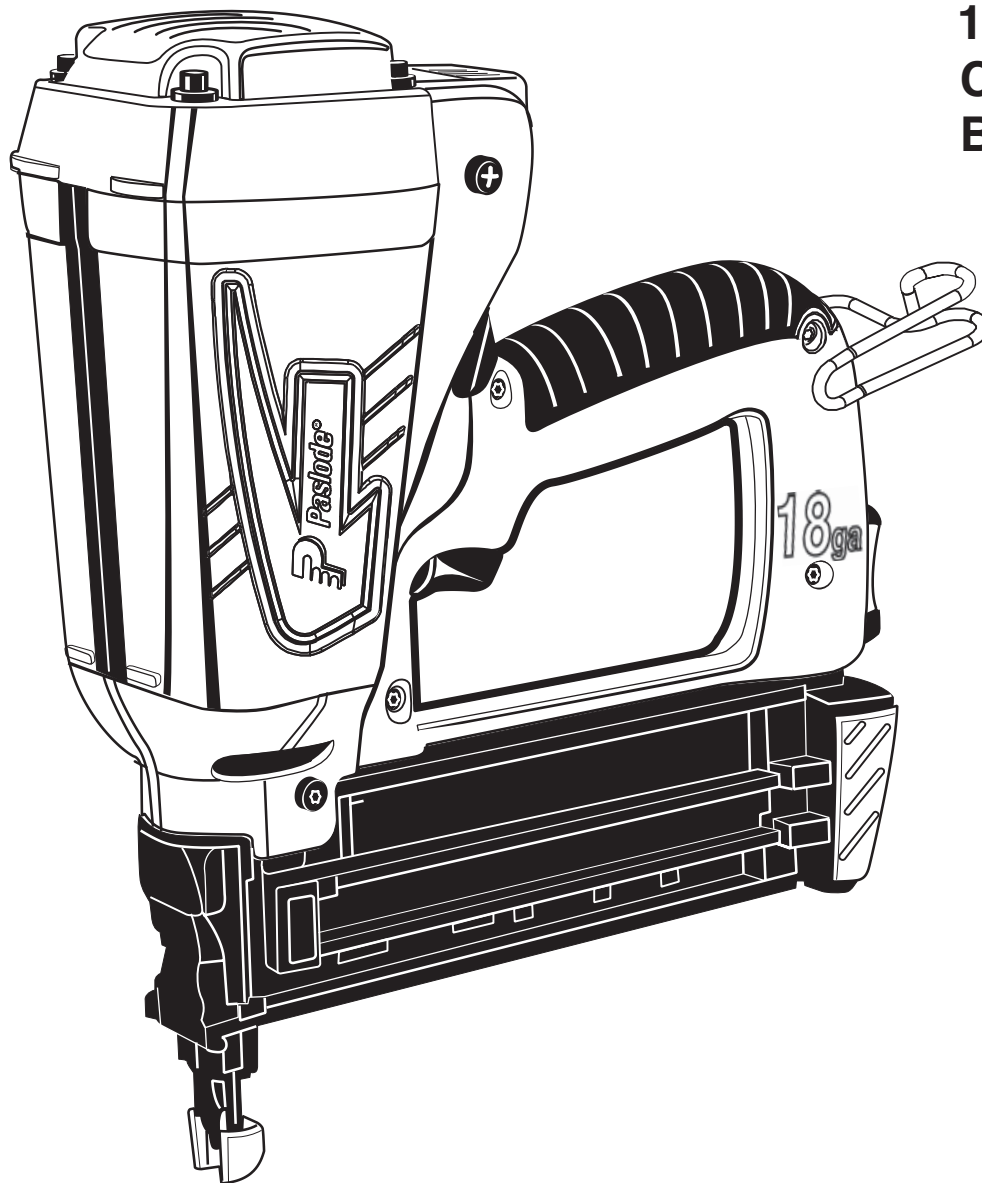

Part No. 918000

**IM200Li  
18 Gauge  
Cordless  
Brad Nailer**



**IMPORTANT!  
DO NOT DESTROY**

Always refer to operators manual #918006 for detailed information on this tool. It is the customers responsibility to have all operators and service personnel read and understand this information.

**TOOL SCHEMATIC AND PARTS**

## PARTS LEGEND

## IM200Li 18 Ga. Cordless Brad Nailer 918000

1	900801	1	Grille, Black	52	901032	2	Bushing, Handle
* 2	900648	1	Filter	53	901095	1	Switch Side Assembly
3	901064	4	S.H.C.S. 8-32 x 1-3/8"	* 54	404922	2	Battery Contact Pad
4	902011	1	Cap, Black	55	918001	1	Label, Name Plate
5	901119	1	Retaining Ring	56	903505	1	Label, Logo Right Side
6	901382	1	Fan Motor Assembly with ring	57	902416	1	Depth of Drive Indicator
7	401356	1	Motor Sleeve	58	903506	1	Label, Left Side
8	900785	1	Spark Plug Sleeve	59	902434	1	Nut, Utility Hook
* 9	900714	1	Spark Plug Assembly	60	902430	1	Button, Utility Hook
10	900674	1	Wire Clip	61	902431	1	Block, Utility Hook
11	900605	1	Cylinder Head	62	902432	1	Spring
* 12	900697	1	Stem Adapter	63	902435	1	Stop
13	900596	1	Screw, Sem 8-32 x 7/16"	64	902430	1	Utility Hook
14	900739	1	Cylinder Head Circuit Board Assembly	65	901036	1	Retaining Ring
15	900612	4	Seal Ring	66	901040	1	Piston Ring
16	900709	1	Fan Assembly	* 67	901078	1	Piston Assembly
17	900700	1	Air Dam	68	901044	1	Soft Grip
18	900729	1	Combustion Chambern Assy.	69	900662	1	ESU Power Wire Assembly
19	900746	2	Screw 8-32 x 7/16 phtx	70	902440	1	Electronic Spark Unit
20	901038	1	Spring	71	901045	1	Trigger
21	901037	1	Yoke	72	901047	1	Trigger Pin
22	901039	1	Yoke Support	73	901053	1	Trigger Spring
23	903726	1	Yoke Guide & Knob Assy.	74	900629	1	HighTension Clip
24	903710	1	Knob Assembly	75	404702	1	Screw 6-32 x 3/8"
25	901009	1	Latch Cover Quick Clear	76	900663	1	Fan Wire Assembly
26	900685	1	Spring Pin	77	903728	1	Spark Plug Wire Assembly
27	901005	1	Latch Clip	78	902439	1	Molded Circuit Assembly
28	901049	1	Spring Pin	79	901019	1	Torsion Spring, Magazine Latch
29	901006	1	Spring Clip Assembly	80	900353	1	Pivot Pin
30	901002	1	Front Plate	81	901014	1	Magazine Latch Release
* 31	901048	1	Probe Tip	82	901061	2	Screw 6-32 x 3/16 BH
32	903704	1	Probe	83	901013	1	Magazine End Cap
33	901026	2	Screw 10-24 x .75	84	901084	1	Magazine Wear Strip Assembly
34	901003	1	Back Plate	■ 85	900660	2	Screw 10-32 x 3/8"
35	901025	1	Support Pin	86	901012	1	Magazine Cover
36	901004	1	Front Plate Support	87	901015	1	Follower
37	901081	1	Sleeve Assembly	88	901018	1	Magazine Pin
38	405140	4	Screw 8-32 x 7/16" (red)	* 89	901055	1	O-ring
39	900668	1	Muffler Cover	90	901052	1	Spring Cover
* 40	900609	1	Muffler	91	901016	1	Constant Force Spring
41	900664	1	Reed Valve	92	901017	1	Spool, Spring
42	900665	1	Reed Plate	93	900748	1	Washer
43	901089	1	Exhaust Baffle	* 94	900735	1	Screw
* 44	900616	1	O-Ring	95	903702	1	Handle Left Side
45	901059	1	Front Channel	96	900703	1	Handle Bracket
46	900598	2	Screw 10-32 x 5/16" (red)	97	900755	1	Bushing Actuator
47	902402	1	Label, Li-Ion + Fuel	98	900788	1	Actuator Assembly
** 48	916003	1	Label, Warning	99	404433	1	Pin Actuator
49	404385	1	Light Pipe	100	901041	1	Wear Strip
50	903701	1	Handle Right Side	101	901062	1	Screw 6-32 x 1/8"
51	900754	2	Screw 8-32 x 1/2" (yellow)	102	901066	4	Screw- Plastite
				* 103	901021	1	Piston Bumper

- \* Denotes Normal Wear Items
- Apply Loctite RC-620 (Green) Part No.401491
- \*\* Make sure Warning Label (916003) is properly affixed replace if necessary.  
Label is available at no charge through the Service Dept.
- Denotes Change

## SAFETY INSTRUCTIONS

### WEAR EYE AND HEARING PROTECTION



Always wear hearing protection and eye protection devices, including side shields when operating or working in the vicinity of a tool.



# IM200Li 18 Ga. Cordless Brad Nailer 918000

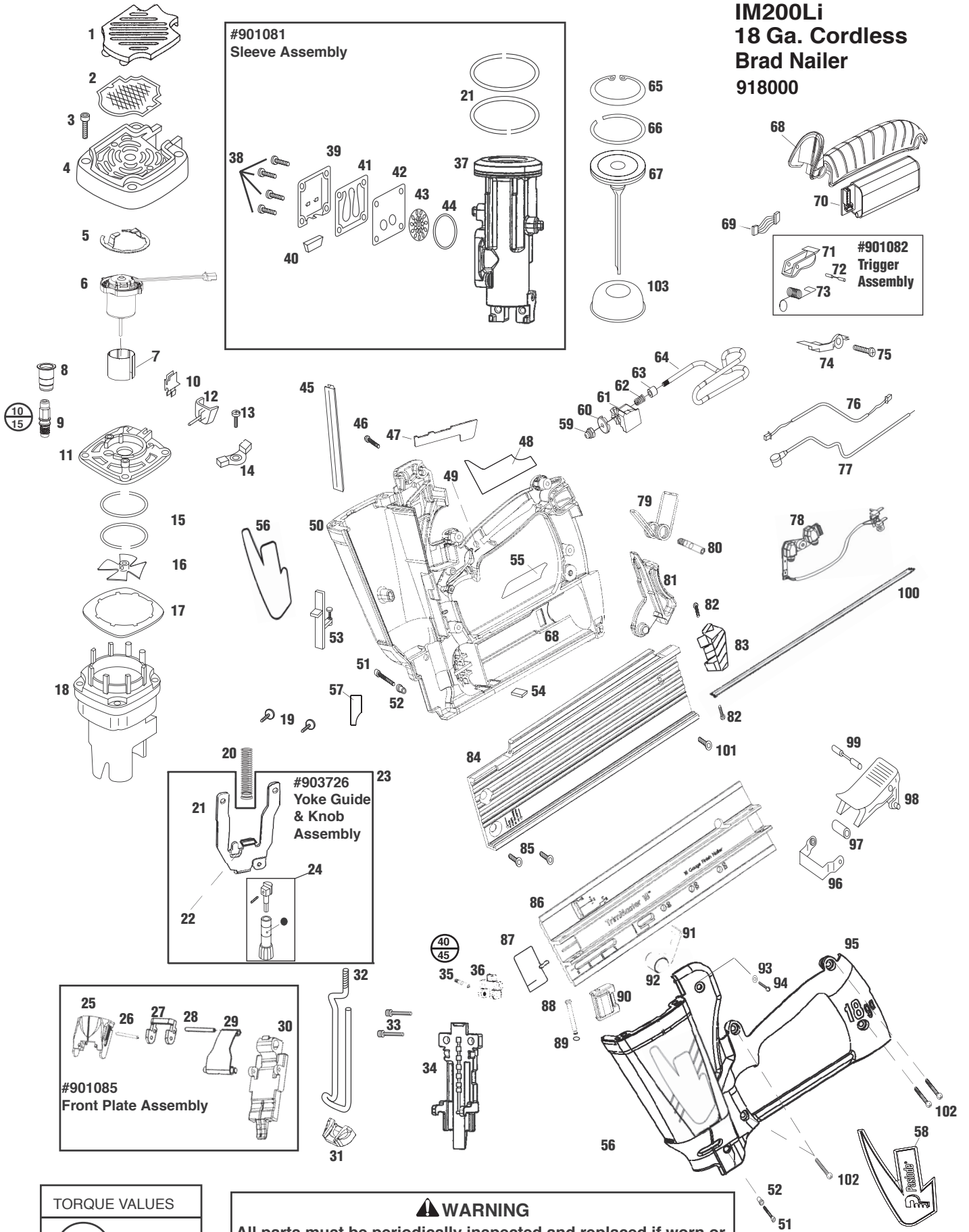

TORQUE VALUES	
MIN	IN/LBS
MAX	

**⚠ WARNING**  
All parts must be periodically inspected and replaced if worn or broken. Failure to do this can affect the tool's operation and present a safety hazard.

# ACCESSORIES

Carrying Case

Part No. 902445

---

Battery



Part No. 902654

---

Paslode Cordless Lubricating Oil



Part No. 401482

---

Torx Key - T7

For tightening fan blade to motor

Part No. 900183

---

Battery Charger

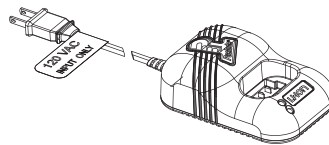

Part No. 902667

---

Clear Safety Glasses



Part No. 401382

---

Tool Cleaner

Ideal cleaner for all Paslode tools



Part No. 219348

---

No- Mar Tip - Hard Tip

Part No. 901048

No- Mar Tip - Soft Tip

Part No. 901067

---



An Illinois Tool Works Co.  
155 Harlem Avenue  
Glenview, IL 60025  
[www.paslode.com](http://www.paslode.com)